



A Smart Renewable Energy Solution

**60W
All-in-One Integrated
Solar LED Street Light**

Specifications

HT-SWD-1H60

Document version: HT-SWD-1H60-SPEC-V1.1

Aug. 2018

Brief Introduction:

All-in-one integrated solar led street light is a new kind of solar led street light for the road and/or area lighting. It is a green and clean renewable energy product. It integrates the high efficient solar panel, super high-output LED lamp, powerful LiFePO4 lithium battery and a smart power management controller system into a slim compact body. In addition, there is a light sensor on the lamp. At daytime, the solar panel can absorb the solar energy for battery charging, while at dusk, the LED lamp will be on automatically and the battery will supply the energy to the lamp for area illumination. What's more, the lamp can be customized with motion sensor or time control mode. Its brightness standard can be adjusted by movement or time schedule. The system continuously monitors the remaining battery charge and regulates light output automatically to extend operating time. It is extremely versatile, robust and perfect suit for those areas where there is sufficient sunlight. It is 100% powered by solar. It has solved the problem of complex installation and expensive transportation compared with traditional solar LED street light. No external cables, then it is very easy for the installation. It is extremely suit for those places where grid power is not available or wiring is not economical or convenient.

Key Features:

- Solar panel, LED lamp, battery, controller all-in-one integrated compact design;
- No external wires or cables needed; Friendly easy installation;
- Using high brightness Bridgelux/Cree chips (LM80) from USA, efficiency upto 210LM/W; LED lamp upto 130LM/W~180LM/W
- Professional optical lens design adopts light transmittance over 95%, light utilization over 60%;
- IP65 modular LED lamp with fast assembly connector;
- High quality monocrystalline PV adopt over 20% conversion efficiency (IPCE);
- MSDS passed high quality lithium Iron phosphate (LiFePO4) battery adopt lifetime over 2000 cycles (5~8 years);
- 100% solar powered green renewable energy;
- Auto turn on at dusk and turn off at dawn;
- PIR motion sensor optional, help to save more power;
- Unique elegant swing-like anti-storm profile design adopts corrosion protection;
- Drawer function design battery holder

Benefits:

- Small volume helps to save freight cost and storage cost;
- No need trenching or wiring job, reduce labor cost and materials cost;
- Renewable energy, no electronic bills any more;
- Professional light distribution design eliminate the light waste;
- High quality durable components ensure 5 to 8 years no maintenance;
- User friendly. Plug & Play design. Fast installation. No need training;
- Green light reduce fossil fuel consumption, eliminating pollution;
- Battery backup for cloudy and rainy days;
- IP65 design suitable for any place where is sufficient sunshine;
- Drawer design easier the possible maintenance of battery and controller;

Applications:

Street, residential road, parking lot, pathway, ramp, farm & ranch lighting, wildlife area, dock & pier, military, personal garden, plaza, highways.....any exterior area wherever there is sufficient sunlight.

Hitechled Optoelectronics Co., Ltd.

Office Add.: 21st F, Bldg. B, GLC Plaza, Baoming 2nd Road, Bao'an district, Shenzhen, China 518102

☎ Tel: +86 755 33653232

☎ Fax: +86 755 33653211

✉ E-mail: sales@hi-techled.com

🌐 Http://www.hi-techled.com

Product Structure Diagram:

PIR Motion Sensor (Optional)

With upto 10m wide range human body infrared rays detector, it gathers automatic convenient, safe, energy-saving, functions. Combined on/off switch

AL Panel

Aluminum alloy protection panel, working as heat-sink board as well

Profile

Casted wing-like aluminum alloy structure, help to reduce the wind stress evenly surface with oxidation treatment

Solar Panel

High quality monocrystalline PV panel with conversion efficiency more than 20%!

Mounting Accessories

Different mounting method optional enhance the stability of lamps. suggested light pole top diameter: 60mm~80mm

Modular LED lamp

Cree 3030 LED chip with optical LENSs Adopts 150°*75° bat-wing beam angle, light utilization more than 80% for street application, light transmittance over 92%, anti-UV, IP65 dustproof & waterproof

Controller

Smart IP65 AL frame controller with multi-period control, charging efficiency & discharging efficiency more than 95%

Waterproof Battery Pack

Lithium Iron Phosphate (LiFePO4) Battery long lifetime upto 2000cycles(5 to 8 years) withstand high temperature upto 70deg. 100% depth of charging and discharging

Drawer System(optional)

Tooled drawer with track and key, Holding the battery pack and controller for easy possible future maintenance.

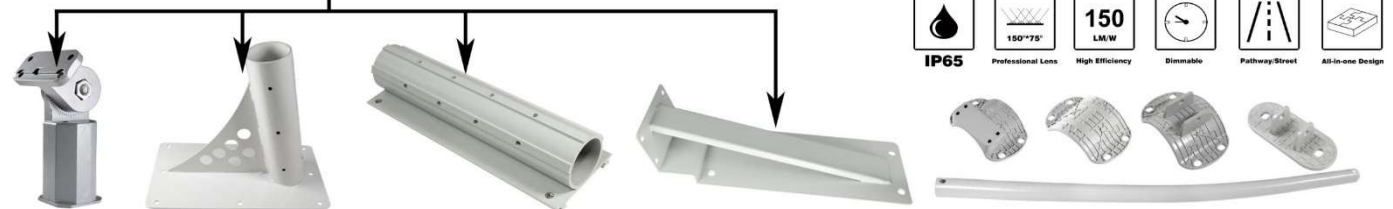

Working Process Introduction:



1st Step: Press the "on/off" button to wake up the system. With the latest combined sensor, when face the solar panel to the sunshine, it would auto wake up the system.



2nd Step: The solar lamp will be off at daytime and start charging when the solar voltage more than 5v.



3rd Step: With the light sensor function, the LED lamp will auto turn on at dusk. It is 30% brightness when standby (if with motion sensor).



4th Step: When movement detected, it will switch to 100% brightness for 30s.



5th Step: If there is no continue movement detected within the sensor area after 30s, it will be standby mode again to save power. The delay time and brightness can be customized.



6th Step: It can be programmed to be time control by time schedule as well. Then during different time phase, it is with different brightness.

HT-SWD-1H60 All-in-one Solar LED Light Specifications:

Parameter		Value
Solar panel (Monocrystalline)	Max power	100W
	Life time	25 years
Battery	Type	538WH LiFePO ₄ battery (adjustable)
	Life time	>2,000 Circles (more than 5 years)
LED Lamp	Max power	96W(drive to be 60w)
	LED chip	Cree 3030 (one module 96pcs; two modules 80pcs)
	Lumen (LM)	6,500-8,000lm
	Life time	50,000hours
	Viewing Angle	150°/75°
Charging time	by sun(strong)	6~7hours
Discharging time	Full power	>10hours
	Dimming mode	3 to 5 days
Working temperature	Range(°C)	-20°C~+65°C
Color temperature	Range(k)	6000k~6500k(optional)
Mounting height	Range (m)	6-10m(suggested) PIR sensor/Time control<8m; Time control>8m;
Space between light	Range (m)	20-30m(suggested)
Housing material	Aluminum alloy	
Certificate	CE / ROHS / IP65	
Packing & Weight	Product size	1160*552*65mm
	NW.for one unit	25kgs
	Carton size	1260*652*160 mm
	Q'ty/ctn	1sets/ctn
	GW.for carton	27kgs
Container load	20GP	144pcs
	40GP	300pcs

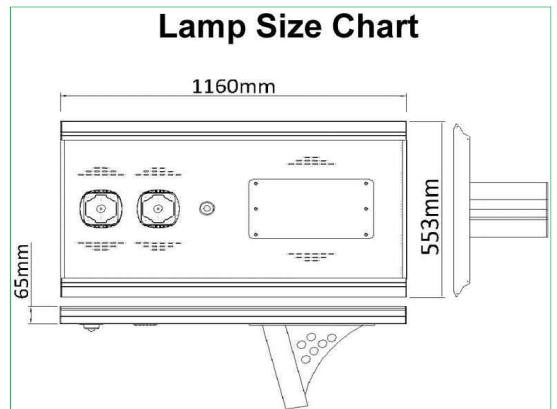

Physical Pictures



Intensity Distribution Diagram

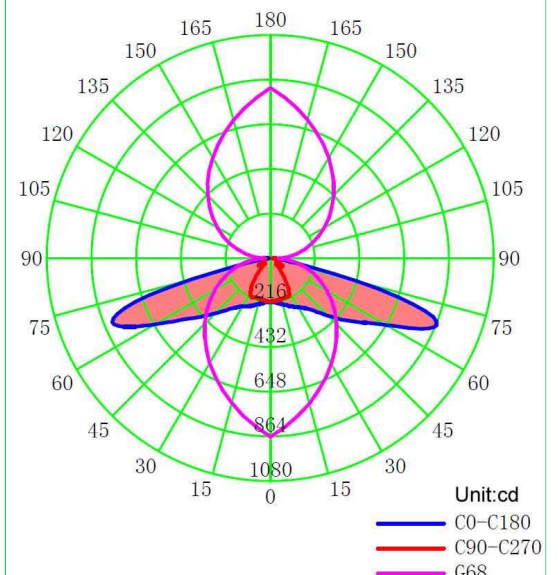

Comparasion:

* Contents are subject to change without prior notice.

Tradtional Light Distribution

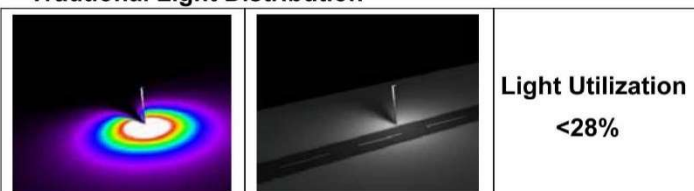

Hitechled All-in-one Solar LED Light Distribution

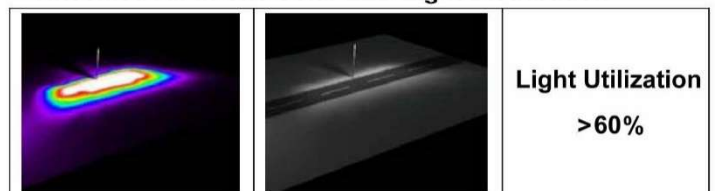

Hitechled Optoelectronics Co.,Ltd.

Office Add.: 21st F, Bldg.B, GLC Plaza, Baoming 2nd Road, Bao'an district, Shenzhen, China 518102

☎ Tel: +86 755 33653232

☎ Fax: +86 755 33653211

✉ E-mail: sales@hi-techled.com

🌐 Http://www.hi-techled.com

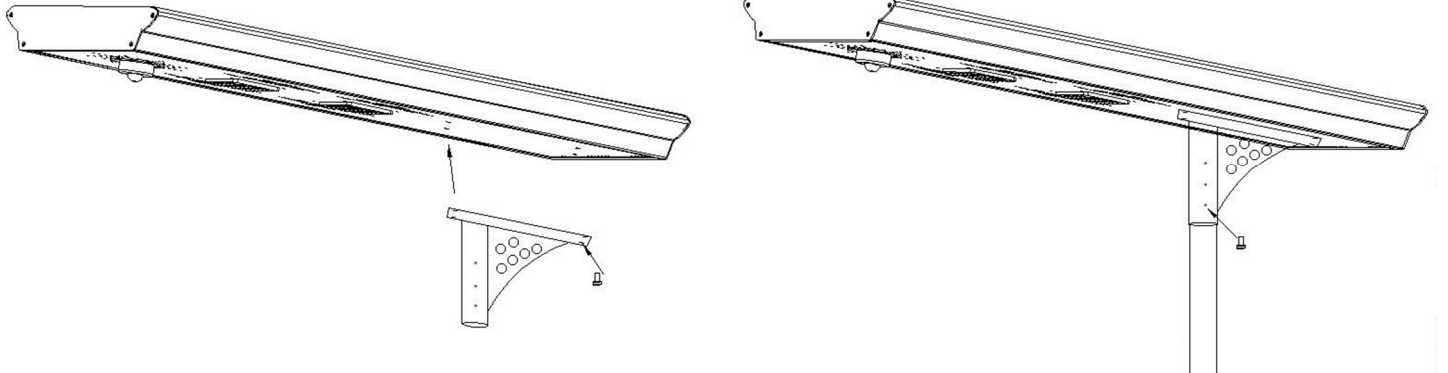
Installation Guide:

Use 4 screws to fix the fitting support on the lamp and fix the lamp on the pole with screws.

Operation Method:

When you press on the switch bottom for 5 seconds (on the sensor), the lamp will start to work. That is all. It is easy to operate without any other operation. Actually, it can auto wakeup when you face the solar panel to the sunlight.

Cautions:

- Integrated solar led street light cannot work without sunshine charging, please select the suitable product model according to the local sunshine radiation and the annual total radiation.
- Integrated solar led street light adopts the long life Lithium battery for storing energy, charging temperature at day time is between: $0^{\circ}\text{C}\sim+65^{\circ}\text{C}$, when temperature goes lower than 0°C , the control system will stop automatically to protect the battery, and it will revive to charge the battery while temperature goes higher than 0°C . Discharging temperature at night is between: $-20^{\circ}\text{C}\sim+65^{\circ}\text{C}$, any ambient beyond will bring damage to the battery. Please confirm your local extreme temperature is suitable for above while selecting the street light.
- Battery of the "integrated solar led street light" can be stored for 6 months long after full charged, and please examine, charge it periodically after long time transportation to prevent damage.
- While installed in Northern Hemisphere, please make sure the surface of the solar panel to be facing the South to collect maximum sunshine radiation, while installed in Southern Hemisphere, please make sure the surface of the solar panel to be facing the North to collect maximum sunshine radiation. At the same time please keep it away from any shadow of house, trees etc.
- Keep cleaning the surface of the integrated solar led street light with normal detergent to get maximum power generation, clean the dust or tree leaves or any grease.
- Please avoid installing under the shadow of trees, building and other blocks.